

THE NEW VALUE FRONTIER

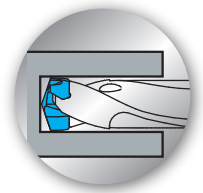

MagicDrill

DRC^{type}

High efficiency

High feed rate

High reliability

High quality

High efficiency drill module

Larger cutting diameters now available

New lineup



SS-DRC
(Straight Shank)



SF-DRC
(Flanged Shank)

Chamfering attachment
(for SS-DRC)

Machining diameters: Ø7.94-Ø20.99

Machining depths: 3D,5D,8D

ADVANCING PRODUCTIVITY

4 unique characteristics of DRC type M as reduce machining cost by high speed

1. Self-Clamping design

- The clamp rigidity and resistance of the Magic Drills self-clamping method has significantly improved with the new design analysis and material technology.
- Easy replacement is possible on the machine.

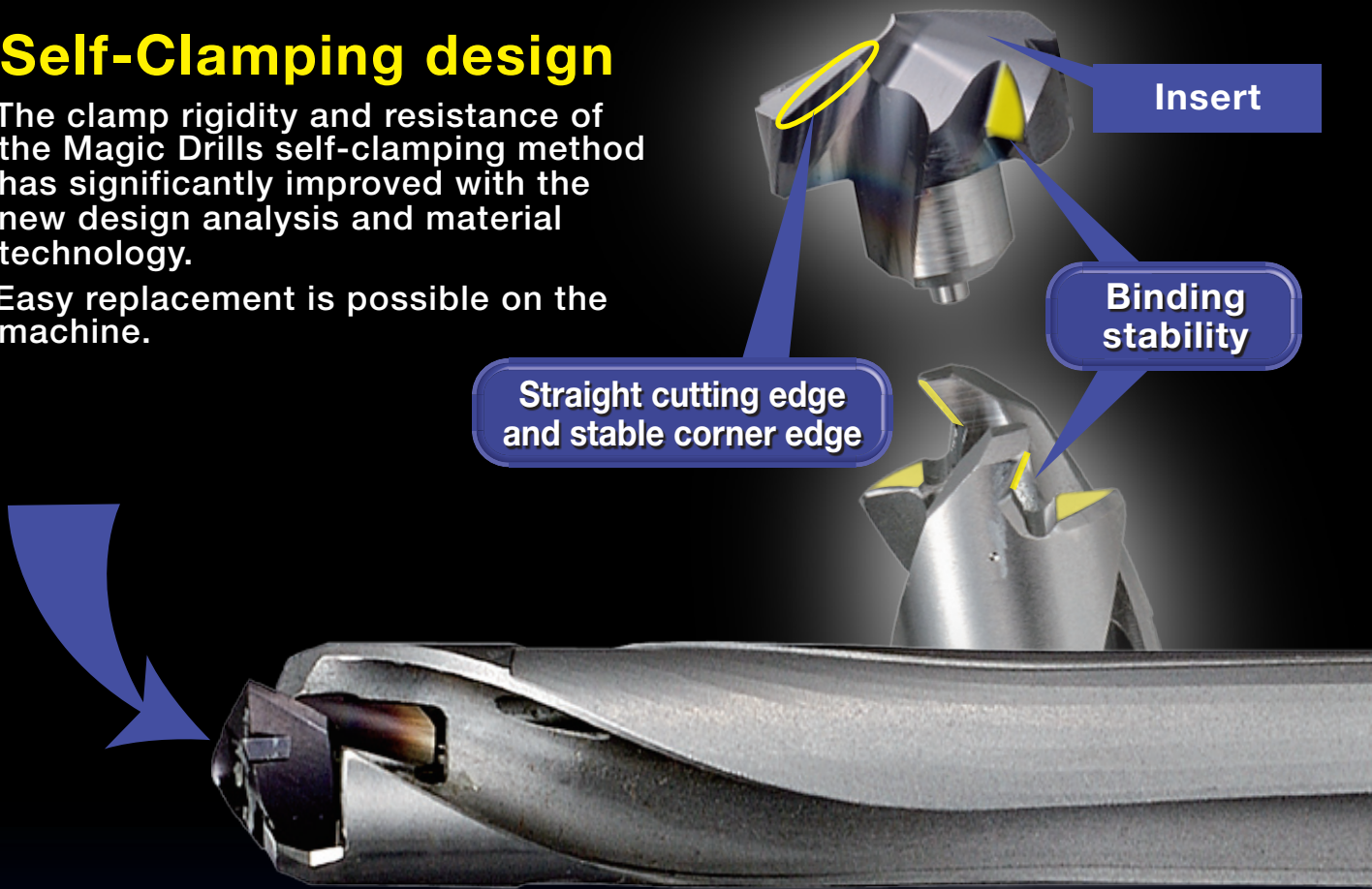

3. Multiple Helical Angle Flute design

- Provides superior drill body stiffness and chip evacuation

4. Direct Cooling design

- The coolant is fed directly into the inserts cutting face, cooling the top of the drill and preventing chip adhesion, which allows for quick and smooth chip evacuation.



agicDrills improve productivity as well as high feed rate machining.

2. Self-Centering design

- The S curve geometry of the tip known as the "Self-Centering design" enables smooth drilling, lower cutting forces and a high quality hole surface.

Self-Centering design

Coolant hole



A chamfering attachment has been added to the lineup. It is now possible to accommodate various types of machines, such as lathes and machining centers.



Insert identification system

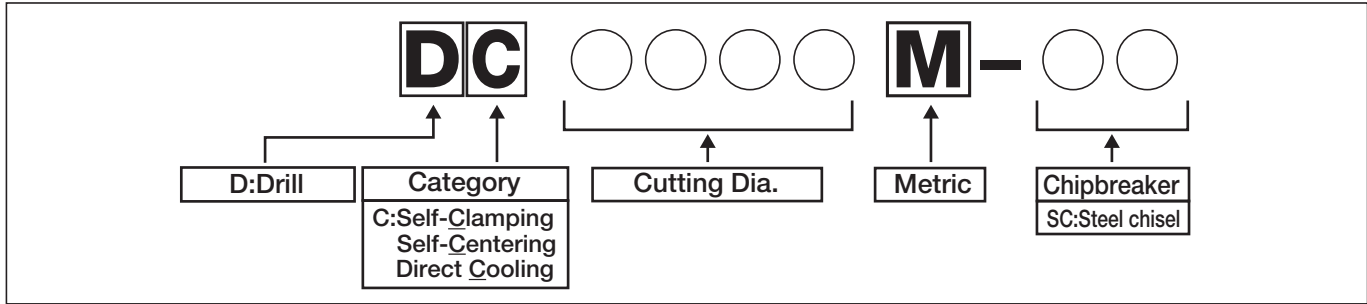

Drilling Inserts

● Insert grade PR0315

PR0315 is tough super micro grain carbide grade with TiAlN coating, with excellent wear resistance and fracture resistance.

It enables stable machining of carbon steel, alloy steel and cast iron.

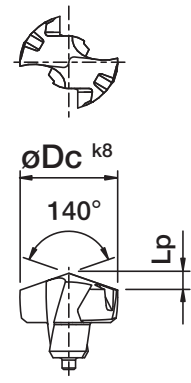
Shape	Description	Dimensions(mm)		PVD Coated	Applicable holder description							
		øDc	Lp	PR0315								
  <p>k8 tolerance</p> <table border="1"> <thead> <tr> <th>øDc</th> <th>k8(mm)</th> </tr> </thead> <tbody> <tr> <td>7.94 ±</td> <td>+0.022 0</td> </tr> <tr> <td>10.10 ±</td> <td>+0.027 0</td> </tr> <tr> <td>18.10 ±</td> <td>+0.033 0</td> </tr> <tr> <td>20.99</td> <td></td> </tr> </tbody> </table> <p>k8 is the dimension tolerance of the insert. It is not the dimension tolerance of the cutting diameter.</p>	øDc	k8(mm)	7.94 ±	+0.022 0	10.10 ±	+0.027 0	18.10 ±	+0.033 0	20.99		New DC 0794M-SC 7.94 1.44 ● 0800M-SC 8.00 1.46 ● 0810M-SC 8.10 1.47 ● 0820M-SC 8.20 1.49 ● 0830M-SC 8.30 1.51 ● 0840M-SC 8.40 1.53 ● DC 0850M-SC 8.50 1.55 ● 0860M-SC 8.60 1.56 ● 0870M-SC 8.70 1.58 ● 0880M-SC 8.80 1.60 ● 0890M-SC 8.90 1.62 ● DC 0900M-SC 9.00 1.64 ● 0910M-SC 9.10 1.66 ● 0920M-SC 9.20 1.67 ● 0930M-SC 9.30 1.69 ● 0940M-SC 9.40 1.71 ● DC 0950M-SC 9.50 1.73 ● 0960M-SC 9.60 1.75 ● 0970M-SC 9.70 1.76 ● 0980M-SC 9.80 1.78 ● 0990M-SC 9.90 1.80 ● DC 1000M-SC 10.00 1.82 ● 1010M-SC 10.10 1.84 ● 1020M-SC 10.20 1.86 ● 1030M-SC 10.30 1.87 ● 1040M-SC 10.40 1.89 ● DC 1050M-SC 10.50 1.91 ● 1060M-SC 10.60 1.93 ● 1070M-SC 10.70 1.95 ● 1080M-SC 10.80 1.96 ● 1090M-SC 10.90 1.98 ● DC 1100M-SC 11.00 2.00 ● 1110M-SC 11.10 2.02 ● 1120M-SC 11.20 2.04 ● 1130M-SC 11.30 2.06 ● 1140M-SC 11.40 2.07 ● DC 1150M-SC 11.50 2.09 ● 1160M-SC 11.60 2.11 ● 1170M-SC 11.70 2.13 ● 1180M-SC 11.80 2.15 ● 1190M-SC 11.90 2.16 ● DC 1200M-SC 12.00 2.18 ● 1210M-SC 12.10 2.20 ● 1220M-SC 12.20 2.22 ● 1230M-SC 12.30 2.24 ● 1240M-SC 12.40 2.26 ●	SS10-DRC080M-○ SF12-DRC080M-○ SS10-DRC085M-○ SF12-DRC085M-○ SS10-DRC090M-○ SF12-DRC090M-○ SS10-DRC095M-○ SF12-DRC095M-○ SS12-DRC100M-○ SF16-DRC100M-○ SS12-DRC105M-○ SF16-DRC105M-○ SS12-DRC110M-○ SF16-DRC110M-○ SS12-DRC115M-○ SF16-DRC115M-○ SS14-DRC120M-○ SF16-DRC120M-○
	øDc	k8(mm)										
	7.94 ±	+0.022 0										
	10.10 ±	+0.027 0										
	18.10 ±	+0.033 0										
	20.99											

Drilling Inserts

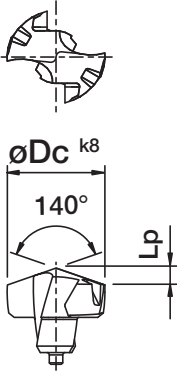
Shape	Description	Dimensions(mm)		PVD Coated	Applicable holder description
		øDc	Lp	PR0315	
 	DC 1250M-SC	12.50	2.27	●	SS14-DRC125M-○ SF16-DRC125M-○
	1260M-SC	12.60	2.29	●	
	1270M-SC	12.70	2.31	●	
	1280M-SC	12.80	2.33	●	
	1290M-SC	12.90	2.35	●	
	DC 1300M-SC	13.00	2.36	●	SS14-DRC130M-○ SF16-DRC130M-○
	1310M-SC	13.10	2.38	●	
	1320M-SC	13.20	2.40	●	
	1330M-SC	13.30	2.42	●	
	1340M-SC	13.40	2.44	●	
	DC 1350M-SC	13.50	2.46	●	SS14-DRC135M-○ SF16-DRC135M-○
	1360M-SC	13.60	2.47	●	
	1370M-SC	13.70	2.49	●	
	1380M-SC	13.80	2.51	●	
	DC 1390M-SC	13.90	2.53	●	SS16-DRC140M-○ SF16-DRC140M-○
	DC 1400M-SC	14.00	2.55	●	
	1410M-SC	14.10	2.56	●	
	1420M-SC	14.20	2.58	●	
	1430M-SC	14.30	2.60	●	
	DC 1440M-SC	14.40	2.62	●	SS16-DRC145M-○ SF16-DRC145M-○
	DC 1450M-SC	14.50	2.64	●	
	1460M-SC	14.60	2.66	●	
	1470M-SC	14.70	2.67	●	
	1480M-SC	14.80	2.69	●	
	DC 1490M-SC	14.90	2.71	●	SS16-DRC150M-○ SF20-DRC150M-○
	DC 1500M-SC	15.00	2.73	●	
	1510M-SC	15.10	2.75	●	
	1520M-SC	15.20	2.76	●	
	1530M-SC	15.30	2.78	●	
	1540M-SC	15.40	2.80	●	
	1550M-SC	15.50	2.82	●	
	1560M-SC	15.60	2.84	●	
	1570M-SC	15.70	2.86	●	
	1580M-SC	15.80	2.87	●	
	DC 1600M-SC	16.00	2.91	●	SS18-DRC160M-○ SF20-DRC160M-○
	1610M-SC	16.10	2.93	●	
	1620M-SC	16.20	2.95	●	
	1630M-SC	16.30	2.96	●	
	1640M-SC	16.40	2.98	●	
	1650M-SC	16.50	3.00	●	
1660M-SC	16.60	3.02	●		
1670M-SC	16.70	3.04	●		
1680M-SC	16.80	3.06	●		
1690M-SC	16.90	3.07	●		
DC 1700M-SC	17.00	3.09	●	SS18-DRC170M-○ SF20-DRC170M-○	
1710M-SC	17.10	3.11	●		
1720M-SC	17.20	3.13	●		
1730M-SC	17.30	3.15	●		
1740M-SC	17.40	3.16	●		
1750M-SC	17.50	3.18	●		
1760M-SC	17.60	3.20	●		
1770M-SC	17.70	3.22	●		
1780M-SC	17.80	3.24	●		
1790M-SC	17.90	3.26	●		
DC 1800M-SC	18.00	3.27	●	SS20-DRC180M-○ SF25-DRC180M-○	
1810M-SC	18.10	3.29	●		
1820M-SC	18.20	3.31	●		
1830M-SC	18.30	3.33	●		
New 1840M-SC	18.40	3.35	●		
New 1850M-SC	18.50	3.36	●		
New 1860M-SC	18.60	3.38	●		
New 1870M-SC	18.70	3.40	●		
1880M-SC	18.80	3.42	●		
New 1890M-SC	18.90	3.44	●		

k8 tolerance

øDc	k8(mm)
7.94 ∩ 10.00	+0.022 0
10.10 ∩ 18.00	+0.027 0
18.10 ∩ 20.99	+0.033 0

k8 is the dimension tolerance of the insert. It is not the dimension tolerance of the cutting diameter.

Inserts are sold in 1 piece quantities.

●:Std stock

Drilling Inserts

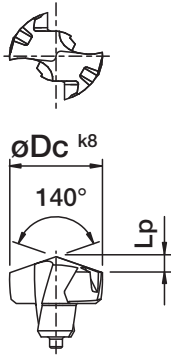
Shape	Description	Dimensions(mm)		PVD Coated	Applicable holder description														
		øDc	Lp	PR0315															
  <p>k8 tolerance</p> <table border="1"> <thead> <tr> <th>øDc</th> <th>k8(mm)</th> </tr> </thead> <tbody> <tr> <td>7.94</td> <td>+0.022 0</td> </tr> <tr> <td>10.00</td> <td></td> </tr> <tr> <td>10.10</td> <td>+0.027 0</td> </tr> <tr> <td>18.00</td> <td></td> </tr> <tr> <td>18.10</td> <td>+0.033 0</td> </tr> <tr> <td>20.99</td> <td></td> </tr> </tbody> </table> <p>k8 is the dimension tolerance of the insert. It is not the dimension tolerance of the cutting diameter.</p>	øDc	k8(mm)	7.94	+0.022 0	10.00		10.10	+0.027 0	18.00		18.10	+0.033 0	20.99		DC 1900M-SC	19.00	3.46	●	SS20-DRC190M-○ SF25-DRC190M-○
	øDc	k8(mm)																	
	7.94	+0.022 0																	
	10.00																		
	10.10	+0.027 0																	
	18.00																		
	18.10	+0.033 0																	
	20.99																		
	DC 1910M-SC	19.10	3.47	●															
	DC 1920M-SC	19.20	3.49	●															
	DC 1930M-SC	19.30	3.51	●															
	DC 1940M-SC	19.40	3.53	●															
	DC 1950M-SC	19.50	3.55	●															
	DC 1960M-SC	19.60	3.56	●															
	DC 1970M-SC	19.70	3.58	●															
	DC 1980M-SC	19.80	3.60	●															
	DC 1990M-SC	19.90	3.62	●															
	DC 2000M-SC	20.00	3.64	●	SS25-DRC200M-○ SF25-DRC200M-○														
	DC 2010M-SC	20.10	3.66	●															
	DC 2020M-SC	20.20	3.67	●															
DC 2030M-SC	20.30	3.69	●																
DC 2040M-SC	20.40	3.71	●																
DC 2050M-SC	20.50	3.73	●																
New DC 2060M-SC	20.60	3.75	●																
New DC 2070M-SC	20.70	3.77	●																
New DC 2080M-SC	20.80	3.78	●																
New DC 2090M-SC	20.90	3.80	●																
New DC 2099M-SC	20.99	3.82	●																

Inserts are sold in 1 piece quantities.

●:Std stock

Recommended cutting conditions

Workpiece Material	Hardness (HB)	Cutting Condition		Cutting Dia.(mm)							Remarks		
		Cutting Speed Vc(m/min)	Spindle Revolution (min ⁻¹) Feed Rate (mm/rev)	ø8	ø10	ø12	ø14	ø16	ø18	ø20			
Low Carbon Steel	SS400 S10C-S25C	125	120 - 180	Spindle Revolution(min ⁻¹)	4,780 - 7,170	3,820 - 5,730	3,180 - 4,780	2,730 - 4,090	2,390 - 3,580	2,120 - 3,180	1,910 - 2,870	With Coolant	
			Feed Rate(mm/rev)	0.11 - 0.20	0.13 - 0.24	0.14 - 0.28	0.17 - 0.32	0.19 - 0.35	0.23 - 0.38	0.25 - 0.41			
Carbon Steel	S30C-S58C (Annealed)	190	100 - 150	Spindle Revolution(min ⁻¹)	3,980 - 5,970	3,180 - 4,780	2,650 - 3,980	2,270 - 3,410	1,990 - 2,990	1,770 - 2,650	1,590 - 2,390		
			Feed Rate(mm/rev)	0.13 - 0.24	0.15 - 0.29	0.17 - 0.33	0.19 - 0.36	0.22 - 0.41	0.25 - 0.46	0.28 - 0.48			
	S30C-S58C (Heat treated)	250	80 - 120	Spindle Revolution(min ⁻¹)	3,180 - 4,780	2,550 - 3,820	2,120 - 3,180	1,820 - 2,730	1,590 - 2,390	1,420 - 2,120	1,270 - 1,910		
			Feed Rate(mm/rev)	0.13 - 0.21	0.15 - 0.25	0.18 - 0.31	0.21 - 0.39	0.23 - 0.45	0.25 - 0.53	0.28 - 0.61			
		300	50 - 75	Spindle Revolution(min ⁻¹)	1,990 - 2,990	1,590 - 2,390	1,330 - 1,990	1,140 - 1,710	1,000 - 1,490	880 - 1,330	800 - 1,190		
			Feed Rate(mm/rev)	0.11 - 0.19	0.12 - 0.23	0.16 - 0.28	0.21 - 0.32	0.23 - 0.35	0.25 - 0.41	0.28 - 0.41			
Alloy Steel	SCM,SCr (Annealed)	180	70 - 95	Spindle Revolution(min ⁻¹)	2,790 - 3,780	2,230 - 3,030	1,860 - 2,520	1,590 - 2,160	1,390 - 1,890	1,240 - 1,680	1,110 - 1,510		
			Feed Rate(mm/rev)	0.15 - 0.28	0.16 - 0.35	0.21 - 0.37	0.23 - 0.46	0.25 - 0.46	0.25 - 0.51	0.30 - 0.51			
	SCM,SCr (Heat treated)	275	70 - 95	Spindle Revolution(min ⁻¹)	2,790 - 3,780	2,230 - 3,030	1,860 - 2,520	1,590 - 2,160	1,390 - 1,890	1,240 - 1,680	1,110 - 1,510		
			Feed Rate(mm/rev)	0.11 - 0.21	0.14 - 0.25	0.19 - 0.30	0.21 - 0.33	0.23 - 0.37	0.28 - 0.43	0.28 - 0.46			
		300	60 - 90	Spindle Revolution(min ⁻¹)	2,390 - 3,580	1,910 - 2,870	1,590 - 2,390	1,360 - 2,050	1,190 - 1,790	1,060 - 1,590	960 - 1,430		
			Feed Rate(mm/rev)	0.11 - 0.19	0.12 - 0.23	0.16 - 0.26	0.18 - 0.31	0.21 - 0.33	0.23 - 0.36	0.25 - 0.38			
			350	50 - 75	Spindle Revolution(min ⁻¹)	1,990 - 2,990	1,590 - 2,390	1,330 - 1,990	1,140 - 1,710	1,000 - 1,490	880 - 1,330		800 - 1,190
				Feed Rate(mm/rev)	0.11 - 0.20	0.12 - 0.23	0.16 - 0.25	0.17 - 0.29	0.18 - 0.32	0.20 - 0.36	0.23 - 0.38		
Stainless Steel	SUS304 SUS316	220	60 - 80	Spindle Revolution(min ⁻¹)	2,390 - 3,180	1,910 - 2,550	1,590 - 2,120	1,360 - 1,820	1,190 - 1,590	1,060 - 1,420	960 - 1,270		
			Feed Rate(mm/rev)	0.11 - 0.19	0.12 - 0.23	0.16 - 0.26	0.18 - 0.31	0.21 - 0.33	0.23 - 0.36	0.25 - 0.38			
	SUS630	300	50 - 70	Spindle Revolution(min ⁻¹)	1,990 - 2,790	1,590 - 2,230	1,330 - 1,860	1,140 - 1,590	1,000 - 1,390	880 - 1,240	800 - 1,110		
			Feed Rate(mm/rev)	0.11 - 0.20	0.12 - 0.23	0.16 - 0.25	0.17 - 0.29	0.18 - 0.32	0.20 - 0.36	0.23 - 0.38			
Gray Cast Iron	FC150-FC200	180	120 - 170	Spindle Revolution(min ⁻¹)	4,780 - 6,770	3,820 - 5,410	3,180 - 4,510	2,730 - 3,870	2,390 - 3,380	2,120 - 3,010	1,910 - 2,710		
			Feed Rate(mm/rev)	0.17 - 0.32	0.20 - 0.37	0.23 - 0.43	0.27 - 0.48	0.30 - 0.55	0.33 - 0.61	0.33 - 0.61			
	FC250-FC350	260	90 - 120	Spindle Revolution(min ⁻¹)	3,580 - 4,780	2,870 - 3,820	2,390 - 3,180	2,050 - 2,730	1,790 - 2,390	1,590 - 2,120	1,430 - 1,910		
			Feed Rate(mm/rev)	0.14 - 0.25	0.16 - 0.31	0.19 - 0.35	0.23 - 0.42	0.26 - 0.47	0.28 - 0.53	0.30 - 0.58			
Nodular Cast Iron	FCD400-FCD500	160	60 - 90	Spindle Revolution(min ⁻¹)	2,390 - 3,580	1,910 - 2,870	1,590 - 2,390	1,360 - 2,050	1,190 - 1,790	1,060 - 1,590	960 - 1,430		
			Feed Rate(mm/rev)	0.14 - 0.25	0.16 - 0.30	0.19 - 0.35	0.22 - 0.40	0.24 - 0.45	0.28 - 0.51	0.28 - 0.56			
	FCD600-FCD800	250	40 - 65	Spindle Revolution(min ⁻¹)	1,590 - 2,590	1,270 - 2,070	1,060 - 1,730	910 - 1,480	800 - 1,290	710 - 1,150	640 - 1,040		
			Feed Rate(mm/rev)	0.10 - 0.19	0.12 - 0.22	0.14 - 0.25	0.16 - 0.31	0.19 - 0.35	0.23 - 0.51	0.25 - 0.53			

Toolholder Identification System

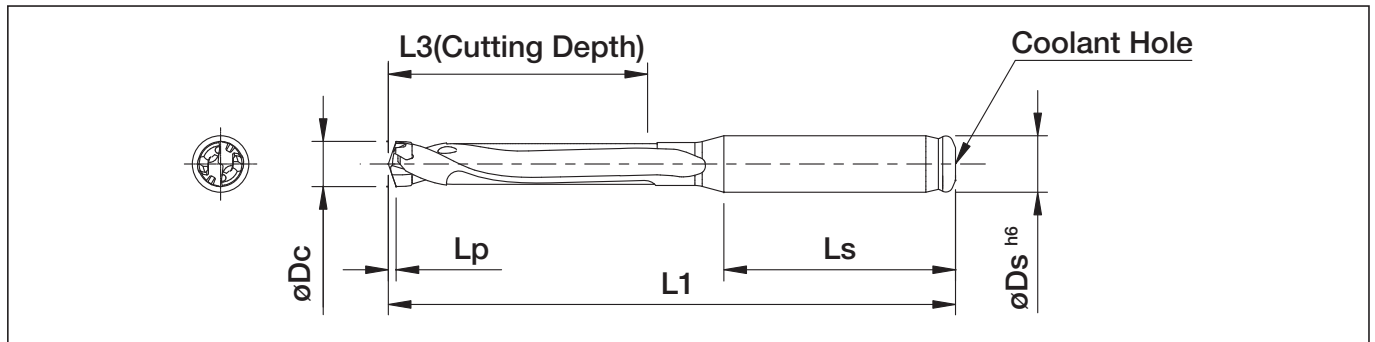
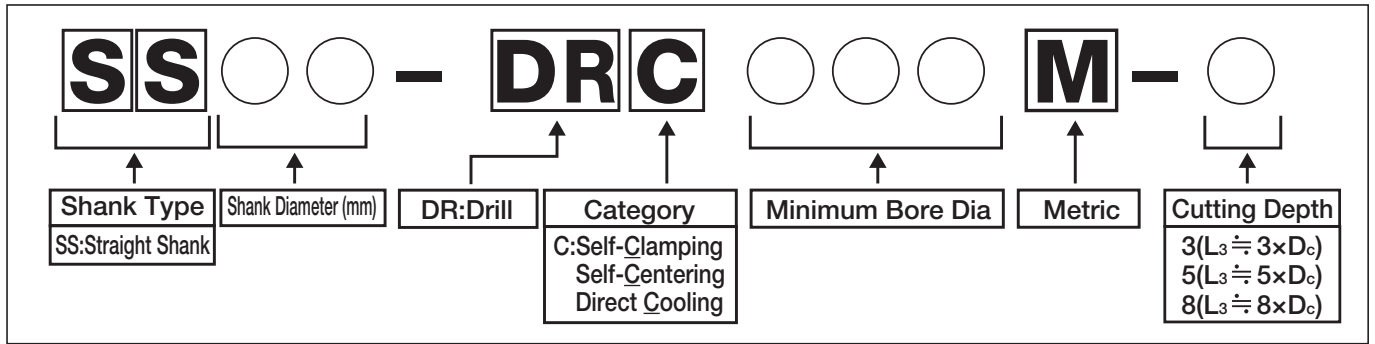

·Lp indicates distance from drill point to corner edge ☉See P3-P5

SS-DRC type (Cutting Depth:3xD)

Toolholder dimensions

Description	stock	Dimensions(mm)						Spare Parts Wrench ☉ See P8	Applicable Insert description	Applicable chamfering Holder and Insert description	
		Applicable Insert Dia. Dc		øDs (h6)	L1	L3	Ls			Holder	Insert
		min.	max.								
SS10- DRC080M-3	●	7.94	8.49	10	79	25.5	40	WDRC8 (WDRC17)	DC0794M-SC-DC0840M-SC	S20-CH10	CT08T2-45A
DRC085M-3	●	8.50	8.99		81	27.0			DC0850M-SC-DC0890M-SC		
DRC090M-3	●	9.00	9.49		83	28.5			DC0900M-SC-DC0940M-SC		
DRC095M-3	●	9.50	9.99		85	30.0			DC0950M-SC-DC0990M-SC		
SS12- DRC100M-3	●	10.00	10.49	12	92	31.5	45	WDRC10 (WDRC17)	DC1000M-SC-DC1040M-SC	S32-CH12	
DRC105M-3	●	10.50	10.99		94	33.0			DC1050M-SC-DC1090M-SC		
DRC110M-3	●	11.00	11.49		96	34.5			DC1100M-SC-DC1140M-SC		
DRC115M-3	●	11.50	11.99		98	36.0			DC1150M-SC-DC1190M-SC		
SS14- DRC120M-3	●	12.00	12.49	14	101	37.5	48	WDRC12 (WDRC17)	DC1200M-SC-DC1240M-SC	S32-CH14	CT12T3-45A
DRC125M-3	●	12.50	12.99		103	39.0			DC1250M-SC-DC1290M-SC		
DRC130M-3	●	13.00	13.49		105	40.5			DC1300M-SC-DC1340M-SC		
DRC135M-3	●	13.50	13.99		107	42.0			DC1350M-SC-DC1390M-SC		
SS16- DRC140M-3	●	14.00	14.49	16	112	43.5	48	WDRC14 (WDRC17)	DC1400M-SC-DC1440M-SC	S32-CH16	
DRC145M-3	●	14.50	14.99		114	45.0			DC1450M-SC-DC1490M-SC		
DRC150M-3	●	15.00	15.99		118	48.0			DC1500M-SC-DC1580M-SC		
SS18- DRC160M-3	●	16.00	16.99	18	122	51.0	49	WDRC17	DC1600M-SC-DC1690M-SC	S32-CH18	
DRC170M-3	●	17.00	17.99		127	54.0			DC1700M-SC-DC1790M-SC		
SS20- DRC180M-3	●	18.00	18.99	20	133	57.0	51	WDRC17	DC1800M-SC-DC1890M-SC	-	-
DRC190M-3	●	19.00	19.99		137	60.0			DC1900M-SC-DC1990M-SC		
SS25- DRC200M-3	●	20.00	20.99	25	147	63.0	57	WDRC17	DC2000M-SC-DC2099M-SC	-	-

●:Std stock

■SS-DRC type (Cutting Depth:5×D)

●Toolholder dimensions

Description	stock	Dimensions(mm)					Spare Parts Wrench ☞ See P8	Applicable Insert description	Applicable chamfering Holder and Insert description		
		Applicable Insert Dia. Dc		øDs (h6)	L1	L3			Ls	Holder	Insert
		min.	max.								
SS10- DRC080M-5	●	7.94	8.49	10	97	42.5	40	WDRC8 (WDRC17)	S20-CH10	CT08T2-45A	
	●	8.50	8.99		100	45.0					
	●	9.00	9.49		103	47.5					
	●	9.50	9.99		107	50.0					
SS12- DRC100M-5	●	10.00	10.49	12	115	52.5	45	WDRC10 (WDRC17)	S32-CH12	CT12T3-45A	
	●	10.50	10.99		118	55.0					
	●	11.00	11.49		121	57.5					
	●	11.50	11.99		124	60.0					
SS14- DRC120M-5	●	12.00	12.49	14	127	62.5	48	WDRC12 (WDRC17)	S32-CH14	CT14T3-45A	
	●	12.50	12.99		130	65.0					
	●	13.00	13.49		133	67.5					
	●	13.50	13.99		137	70.0					
SS16- DRC140M-5	●	14.00	14.49	16	143	72.5	48	WDRC14 (WDRC17)	S32-CH16	CT16T3-45A	
	●	14.50	14.99		146	75.0					
	●	15.00	15.99		152	80.0					
SS18- DRC160M-5	●	16.00	16.99	18	158	85.0	49	WDRC16 (WDRC17)	S32-CH18	CT18T3-45A	
	●	17.00	17.99		165	90.0					
SS20- DRC180M-5	●	18.00	18.99	20	173	95.0	51	WDRC17	-	-	
	●	19.00	19.99		179	100.0					
SS25- DRC200M-5	●	20.00	20.99	25	191	105.0	57	WDRC17	-	-	

●:Std stock

●Drilling and chamfering simultaneously

By using the chamfering attachment, the SS-DRC can perform drilling and chamfering in one set up.



Please refer to pages 9 and 10 for details on the chamfering attachment



■SS-DRC type (Cutting Depth:8xD)

●Toolholder dimensions

Description	stock	Dimensions(mm)					Spare Parts Wrench ⊕ See P8	Applicable Insert description	Applicable chamfering Holder and Insert description		
		Applicable Insert Dia. Dc		øDs (h6)	L1	L3			Ls	Holder	Insert
		min.	max.								
SS10- DRC080M-8	●	7.94	8.49	10	122.5	68	40	WDRC8 (WDRC17)	DC0794M-SC~DC0840M-SC	S20-CH10	CT08T2-45A
	●	8.50	8.99		127.0	72					
	●	9.00	9.49		131.5	76					
	●	9.50	9.99		137.0	80					
SS12- DRC100M-8	●	10.00	10.49	12	146.5	84	45	WDRC10 (WDRC17)	DC1000M-SC~DC1040M-SC	S32-CH12	CT12T3-45A
	●	10.50	10.99		151.0	88					
	●	11.00	11.49		155.5	92					
	●	11.50	11.99		160.0	96					
SS14- DRC120M-8	●	12.00	12.49	14	164.5	100	48	WDRC12 (WDRC17)	DC1200M-SC~DC1240M-SC	S32-CH14	CT12T3-45A
	●	12.50	12.99		169.0	104					
	●	13.00	13.49		173.5	108					
	●	13.50	13.99		179.0	112					
SS16- DRC140M-8	●	14.00	14.49	16	186.5	116	49	WDRC14 (WDRC17)	DC1400M-SC~DC1440M-SC	S32-CH16	CT16T3-45A
	●	14.50	14.99		191.0	120					
	●	15.00	15.99		200.0	128					
SS18- DRC160M-8	●	16.00	16.99	18	209.0	136	50	WDRC16 (WDRC17)	DC1600M-SC~DC1690M-SC	S32-CH18	CT18T3-45A
	●	17.00	17.99		219.0	144					
SS20- DRC180M-8	●	18.00	18.99	20	230.0	152	51	WDRC17	DC1800M-SC~DC1890M-SC	-	-
	●	19.00	19.99		239.0	160					
SS25- DRC200M-8	●	20.00	20.99	25	254.0	168	57	WDRC17	DC2000M-SC~DC2099M-SC	-	-

●:Std stock

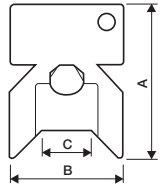
■Wrench for installing inserts

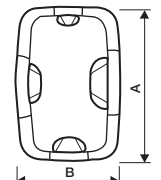
Shape		Description	Dimensions(mm)			Remarks
			A	B	C	
		WDRC8	43	33	ø10.2	 Description is printed in this area.
		WDRC10			ø12.2	
		WDRC12			ø14.2	
		WDRC14			ø17.2	
		WDRC17	77	52	-	·WDRC17(Multiple type wrench) has four insert entry points. If using an insert ranging from DC1700M-SC to DC2099M-SC, use the entry point printed as "ø17.00~ø20.99". ·WDRC17 can be used instead of WDRC8~14 wrench.

■ Chamfering attachment

● Toolholder

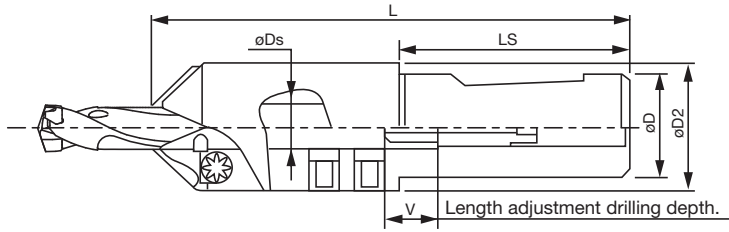

Description	stock	Applicable Drill Dia. Ds	Dimensions(mm)					Applicable insert
			øD	øD2	L	LS	V	
S20-CH10	●	10	20	29	122	52	17	CT08T2-45A
S32-CH12	●	12	32	38	133	62	21	CT12T3-45A
S32-CH14	●	14		40	137		16	
S32-CH16	●	16		42	141		19	
S32-CH18	●	18		47	144		15	

●:Std stock

● Drilling and chamfering depths

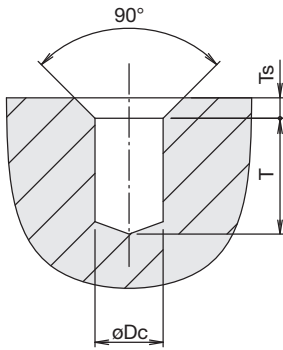

Cutting Dia.(mm)		Drilling depth(mm)						Chamfering dimension (mm)		Applicable toolholder
øDc		T (3XD Drill)		T (5XD Drill)		T (8XD Drill)		Ts		
min	max	min	max	min	max	min	max	Ts 100	Ts max	
ø7.94	ø8.49	11	19	21	37	47	63	2.5	5.0	S20-CH10
ø8.50	ø8.99	12	21	24	40	51	67			
ø9.00	ø9.49	12	23	27	43	56	72			
ø9.50	ø9.99	13	25	31	47	61	77			
ø10.00	ø10.49	13	26	28	49	60	81	3.5	7.0	S32-CH12
ø10.50	ø10.99	14	28	31	52	64	85			
ø11.00	ø11.49	14	30	34	55	69	90			
ø11.50	ø11.99	15	32	37	58	73	94			
ø12.00	ø12.49	15	30	41	56	79	94	4.0	8.0	S32-CH14
ø12.50	ø12.99	17	32	44	59	83	96			
ø13.00	ø13.49	19	34	47	62	88	103			
ø13.50	ø13.99	21	36	51	66	93	108			
ø14.00	ø14.49	19	37	50	68	94	112	4.0	8.0	S32-CH16
ø14.50	ø14.99	21	39	53	71	98	116			
ø15.00	ø15.99	25	43	59	77	107	125			
ø16.00	ø16.99	30	44	66	80	117	131			
ø17.00	ø17.99	35	49	73	87	127	141	4.0	8.0	S32-CH18

Ts 100:Max chamfering dimension at the full feed.
Ts max:Max chamfering dimension at a 50% feed reduction.

●Applicable chamfering insert

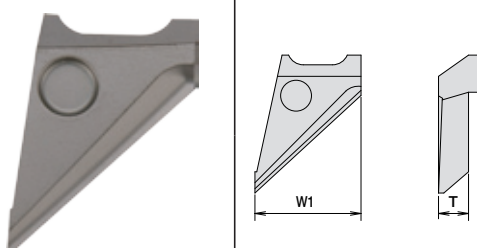
Shape	Description	Dimensions(mm)		PVD Coated	Applicable toolholder
		W1	T	PR0315	
	CT08T2-45A	8	2.83	●	S20-CH10
	CT12T3-45A	12	3.98	●	S32-CH12 S32-CH18

Inserts are sold in 10 piece quantities. ●:Std stock

●Method to use DRC chamfering attachment

1. Drilling depth adjustment

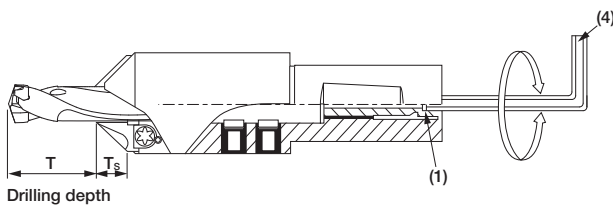

- Insert drill into chamfering attachment.
- Next, temporarily attach the chamfering insert A.
- Turn the adjusting screw (1) with the hexagon wrench (4) to set the drilling depth T.

2. Drill location check

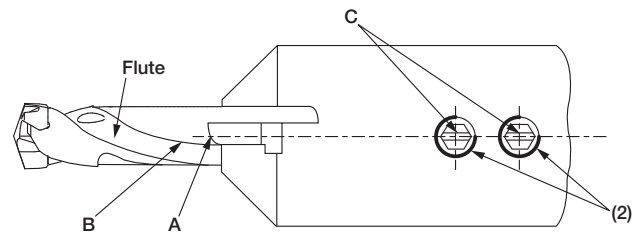

- Rotate the drill so that the lower end of the chamfering insert A is aligned with the body clearance B of the drill.
- Set it so that slot C and the drill fitting screws (2) are lined up as shown in the figure above.

3. Fix the drill

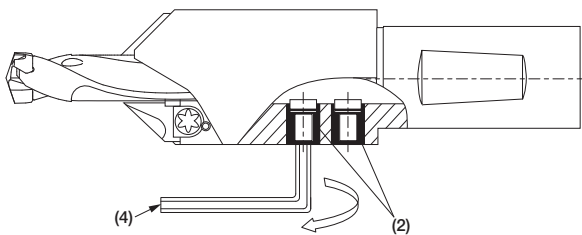

- Tighten the drill fitting screws (2) with the hexagon wrench (4).
(In the case of using a torque wrench, then please refer to the table below.)

4. Installation of the chamfering insert

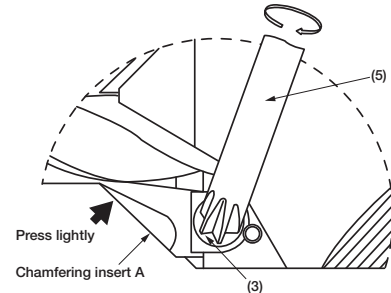

- Press the chamfering insert A lightly into the drill and tighten the insert mounting screw (3) with wrench (5).

Chamfering attachment	Torque [Nm]	Adjusting screw	Drill fitting screw	Insert mounting screw	Hexagon wrench	wrench
S20-CH10	10	AJ-6×38	FS-10	MT-3	LW-3	DT-9
S32-CH12	15	AJ-8×44-9.5	FS-12	MT-4		LW-4
S32-CH14	20	AJ-10×46	FS-14			
S32-CH16	30		FS-16			
S32-CH18	45		FS-18		LW-5	

Toolholder Identification System

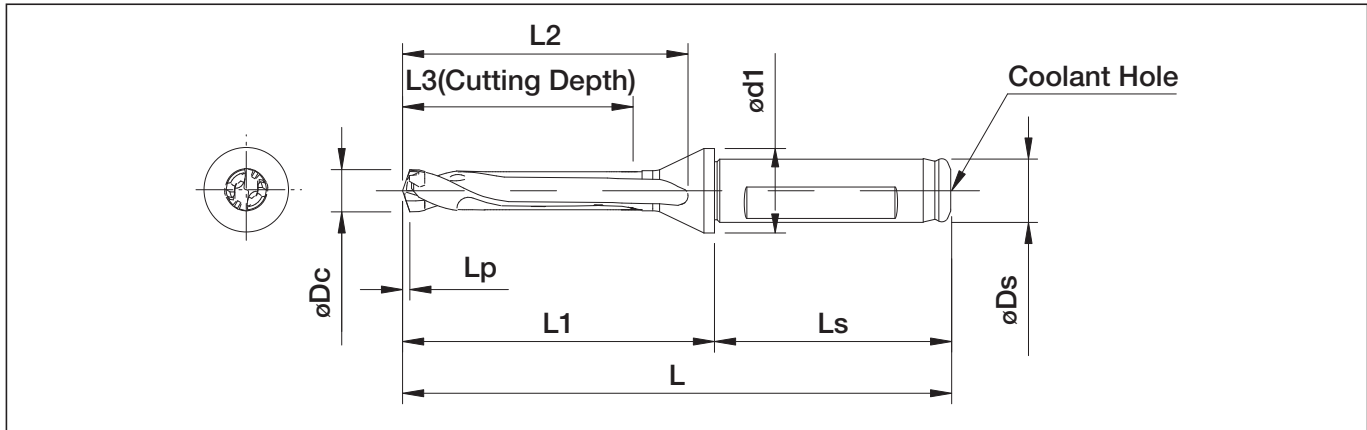
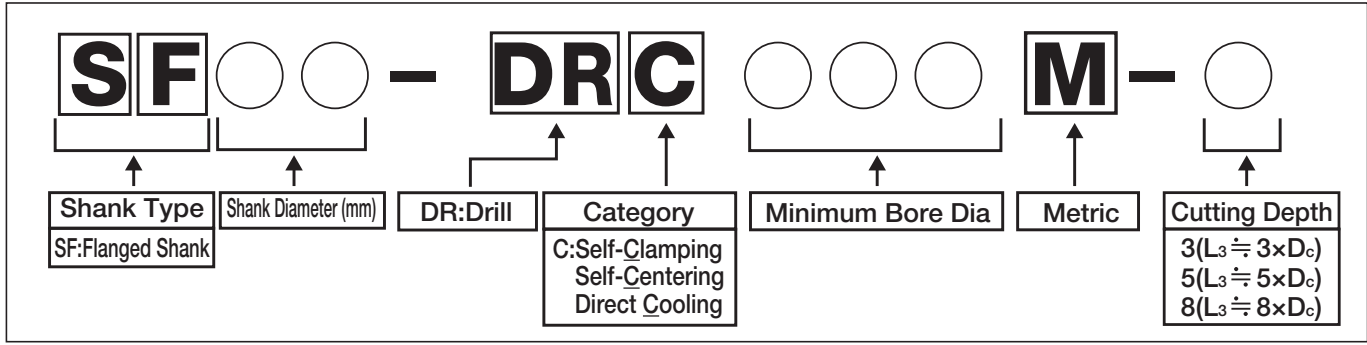

·Lp indicates distance from drill point to corner edge ➔ See P3-P5

SF-DRC type (Cutting Depth: 3×D)

Toolholder dimensions

Description	stock	Dimensions(mm)								Spare Parts	Applicable insert		
		Applicable Insert Dia. Dc		øDs (h6)	L	L1	L2	L3	Ls			ød1	
		min.	max.										
SF12- DRC080M-3	●	7.94	8.49	12	86	41	35	26	45	16	WDRC8 (WDRC17)	DC0794M-SC-DC0840M-SC	
	●	8.50	8.99		88	43	37	27	45			DC0850M-SC-DC0890M-SC	
	●	9.00	9.49		90	45	39	29	45			DC0900M-SC-DC0940M-SC	
	●	9.50	9.99		92	47	41	30	45			DC0950M-SC-DC0990M-SC	
SF16- DRC100M-3	●	10.00	10.49	16	97	49	43	32	48	20	WDRC10 (WDRC17)	DC1000M-SC-DC1040M-SC	
	●	10.50	10.99		99	51	45	33	48			DC1050M-SC-DC1090M-SC	
	●	11.00	11.49		101	53	47	35	48			DC1100M-SC-DC1140M-SC	
	●	11.50	11.99		103	55	49	36	48			DC1150M-SC-DC1190M-SC	
	●	12.00	12.49		106	58	52	38	48		WDRC12 (WDRC17)	DC1200M-SC-DC1240M-SC	
	●	12.50	12.99		108	60	54	39	48			DC1250M-SC-DC1290M-SC	
	●	13.00	13.49		110	62	56	41	48			DC1300M-SC-DC1340M-SC	
	●	13.50	13.99		112	64	58	42	48			DC1350M-SC-DC1390M-SC	
	●	14.00	14.49		114	66	60	44	48			WDRC14 (WDRC17)	DC1400M-SC-DC1440M-SC
	●	14.50	14.99		116	68	62	45	48				DC1450M-SC-DC1490M-SC
SF20- DRC150M-3	●	15.00	15.99	20	122	72	66	48	50	25	WDRC14 (WDRC17)	DC1500M-SC-DC1580M-SC	
	●	16.00	16.99		126	76	70	51	50			DC1600M-SC-DC1690M-SC	
	●	17.00	17.99		131	81	75	54	50			DC1700M-SC-DC1790M-SC	
SF25- DRC180M-3	●	18.00	18.99	25	141	85	79	57	56	32	WDRC17	DC1800M-SC-DC1890M-SC	
	●	19.00	19.99		145	89	83	60	56			DC1900M-SC-DC1990M-SC	
	●	20.00	20.99		149	93	87	63	56			DC2000M-SC-DC2099M-SC	

●: Std stock

■SF-DRC type(Cutting Depth:5×D)

●Toolholder dimensions

Description	stock	Dimensions(mm)									Spare Parts	Applicable insert	
		Applicable Insert Dia. Dc		øDs (h6)	L	L1	L2	L3	Ls	ød1			Wrench ↻ See P8
		min.	max.										
SF12- DRC080M-5	●	7.94	8.49	12	104	59	53	43	45	16	WDRC8 (WDRC17)	DC0794M-SC~DC0840M-SC	
	●	8.50	8.99		107	62	56	45	45			DC0850M-SC~DC0890M-SC	
	●	9.00	9.49		110	65	59	48	45			DC0900M-SC~DC0940M-SC	
	●	9.50	9.99		114	69	63	50	45			DC0950M-SC~DC0990M-SC	
SF16- DRC100M-5	●	10.00	10.49	16	120	72	66	53	48	20	WDRC10 (WDRC17)	DC1000M-SC~DC1040M-SC	
	●	10.50	10.99		123	75	69	55	48			DC1050M-SC~DC1090M-SC	
	●	11.00	11.49		126	78	72	58	48			DC1100M-SC~DC1140M-SC	
	●	11.50	11.99		129	81	75	60	48			DC1150M-SC~DC1190M-SC	
	●	12.00	12.49		132	84	78	63	48		WDRC12 (WDRC17)	DC1200M-SC~DC1240M-SC	
	●	12.50	12.99		135	87	81	65	48			DC1250M-SC~DC1290M-SC	
	●	13.00	13.49		138	90	84	68	48			DC1300M-SC~DC1340M-SC	
	●	13.50	13.99		142	94	88	70	48			DC1350M-SC~DC1390M-SC	
	●	14.00	14.49		145	97	91	73	48			WDRC14 (WDRC17)	DC1400M-SC~DC1440M-SC
	●	14.50	14.99		148	100	94	75	48				DC1450M-SC~DC1490M-SC
SF20- DRC150M-5	●	15.00	15.99	20	156	106	100	80	50	25	WDRC17 (WDRC17)	DC1500M-SC~DC1580M-SC	
	●	16.00	16.99		162	112	106	85	50			DC1600M-SC~DC1690M-SC	
	●	17.00	17.99		169	119	113	90	50			DC1700M-SC~DC1790M-SC	
SF25- DRC180M-5	●	18.00	18.99	25	181	125	119	95	56	32	WDRC17	DC1800M-SC~DC1890M-SC	
	●	19.00	19.99		187	131	125	100	56			DC1900M-SC~DC1990M-SC	
	●	20.00	20.99		193	137	131	105	56			DC2000M-SC~DC2099M-SC	

●:Std stock

■SF-DRC type(Cutting Depth:8×D)

●Toolholder dimensions

Description	stock	Dimensions(mm)									Spare Parts	Applicable insert	
		Applicable Insert Dia. Dc		øDs (h6)	L	L1	L2	L3	Ls	ød1			Wrench ↻ See P8
		min.	max.										
SF12- DRC080M-8	●	7.94	8.49	12	129	84	79	68	45	16	WDRC8 (WDRC17)	DC0794M-SC~DC0840M-SC	
	●	8.50	8.99		134	89	83	72	45			DC0850M-SC~DC0890M-SC	
	●	9.00	9.49		138	93	88	76	45			DC0900M-SC~DC0940M-SC	
	●	9.50	9.99		144	99	93	80	45			DC0950M-SC~DC0990M-SC	
SF16- DRC100M-8	●	10.00	10.49	16	151	103	97	84	48	20	WDRC10 (WDRC17)	DC1000M-SC~DC1040M-SC	
	●	10.50	10.99		156	108	102	88	48			DC1050M-SC~DC1090M-SC	
	●	11.00	11.49		160	112	107	92	48			DC1100M-SC~DC1140M-SC	
	●	11.50	11.99		165	117	111	96	48			DC1150M-SC~DC1190M-SC	
	●	12.00	12.49		169	121	116	100	48		WDRC12 (WDRC17)	DC1200M-SC~DC1240M-SC	
	●	12.50	12.99		174	126	120	104	48			DC1250M-SC~DC1290M-SC	
	●	13.00	13.49		178	130	124	108	48			DC1300M-SC~DC1340M-SC	
	●	13.50	13.99		184	136	130	112	48			DC1350M-SC~DC1390M-SC	
	●	14.00	14.49		188	140	134	116	48			WDRC14 (WDRC17)	DC1400M-SC~DC1440M-SC
	●	14.50	14.99		193	145	139	120	48				DC1450M-SC~DC1490M-SC
SF20- DRC150M-8	●	15.00	15.99	20	204	154	148	128	50	25	WDRC17 (WDRC17)	DC1500M-SC~DC1580M-SC	
	●	16.00	16.99		213	163	157	136	50			DC1600M-SC~DC1690M-SC	
	●	17.00	17.99		223	173	167	144	50			DC1700M-SC~DC1790M-SC	
SF25- DRC180M-8	●	18.00	18.99	25	238	182	176	152	56	32	WDRC17	DC1800M-SC~DC1890M-SC	
	●	19.00	19.99		247	191	185	160	56			DC1900M-SC~DC1990M-SC	
	●	20.00	20.99		256	200	194	168	56			DC2000M-SC~DC2099M-SC	

●:Std stock

Method to change DRC type Magic Drill inserts

How to attach inserts



- 1) Fix drill holder on arbor. For insert exchange, fix arbor on the machine or set on toolpresetter.
- 2) Remove dust using air blow.



- 3) Install insert onto holder.
(Use gloves to protect your hand from any danger.)



- 4) Turn lightly in a clockwise direction.
(Use gloves to protect your hand from any danger.)

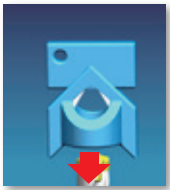

- 5) Align the wrench properly with the insert.

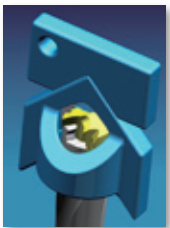

- 6) Make sure the wrench is aligned with the wrench slots on the insert.

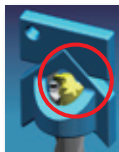

(Improper alignment shown)



Slot for wrench



- 7) Turn the wrench in a slow counterclockwise direction.
- 8) Completed.

How to detach inserts

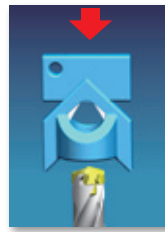

- 1) Remove dust from insert using air blast.
- 2) Align the wrench properly with the insert.



- 3) Make sure the wrench is aligned with the wrench slots on the insert.



- 4) Turn the wrench in a counterclockwise direction.



- 5) Once lock is released, insert can be turned by fingers.
(Use gloves to protect your hand from any danger.)



- 6) Remove insert.
(Use gloves to protect your hand from any danger.)

Coolant

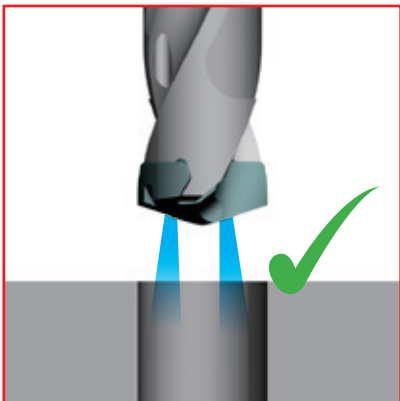

- 1) Internal coolant is recommended.

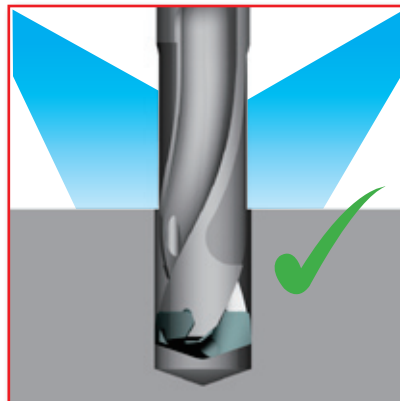

- 2) In case of external coolant
Cutting depth must be 3xD or less.

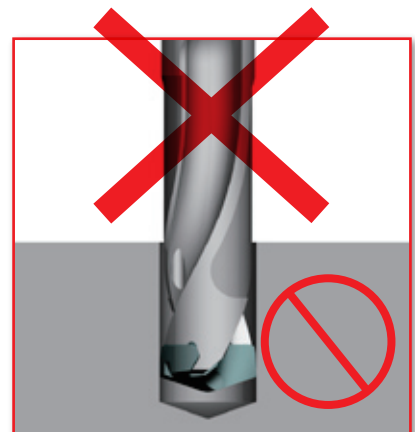

- 3) Dry cutting is not recommended.

■ Precautions for use

● Core Deviation

1) If drill is stationary

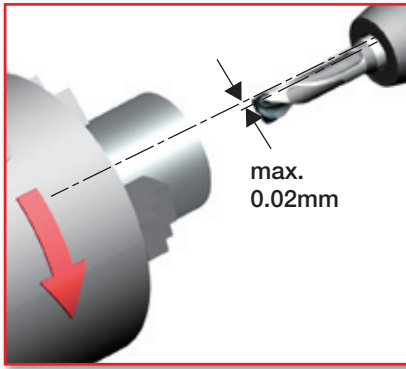

This is usable for boring sleeve (screw clamp) and collet-chuck, please be sure to set deviation amount under 0.02mm between workpiece and drill.

2) If drill is rotating

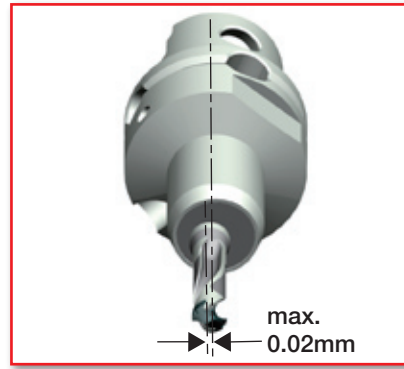

Make sure to use arbor that is not deformed. Center of arbor deviation must be within 0.02mm.

■ Applicable workpiece

Application	Workpiece Shape	Caution for machining
Flat Face		<ol style="list-style-type: none"> 1. Due to good chip control, step machining is not necessary for soft steel like SS400. 2. When machining SUS304, for hole depths of more than 2.5D, utilize the step machining process. 3. In order to have smooth chip removal, we recommend internal coolant.
Stacked Plates		<ol style="list-style-type: none"> 1. Fix stacked plates securely to ensure they do not slip while machining.
Hole Expansion		<ol style="list-style-type: none"> 1. If the overlap amount is less than $1/3 \times D$, machining is possible.
Concave Surface		<ol style="list-style-type: none"> 1. When machining concave holes set the feed rates at half or less than continuous hole machining.
Pipe Material		<ol style="list-style-type: none"> 1. Hole machining above the centerline of the pipe is possible. 2. Do not machine on curved surface areas.

■ Not recommended workpieces

Application	Workpiece Shape
Slanted Surface	

Application	Workpiece Shape
Half Cylindrical	

Application	Workpiece Shape
Cored Hole	

Reference charts

<Cutting Condition>: Heat treated steel(Hardness 240HB) Vc=80m/min, Wet

Power required

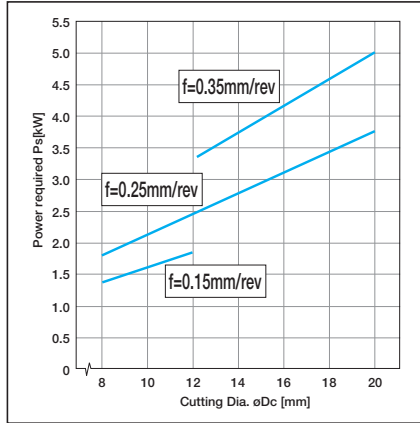

Thrust force

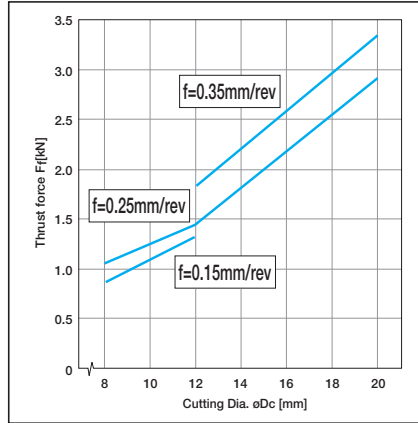

Torque

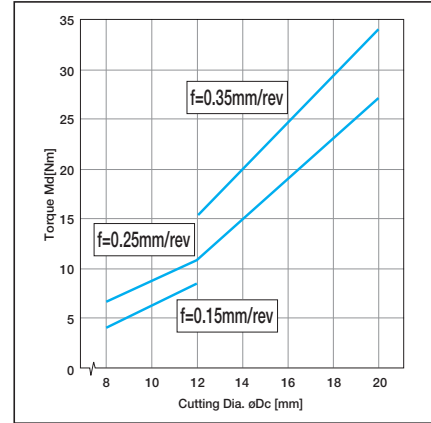

Case Studies

S50C

- Flange
- Vc=97m/min (n=2,490min⁻¹)
- H=32mm
- f=0.3mm/rev (Vf=747mm/min)
- Wet (Internal Coolant)
- DC1250M-SC (PR0315)

SS14-DRC120M-3	3,000holes/insert
Competitor A	1,800holes/drill

• Compared to competitor's drill A, MagicDrill DRC type has reduced burr and reduced more than 10% of the power required. Tool life has also improved greatly.

(Evaluation by the user)

SCM440

- Housing
- Vc=83m/min (n=2,400min⁻¹)
- H=32mm
- f=0.24mm/rev (Vf=576mm/min)
- Wet (Internal Coolant)
- DC1100M-SC (PR0315)

SS12-DRC110M-3	more than 2,400holes/insert
Competitor B	2,000holes/drill

• Compared to competitor's solid drill B, MagicDrill DRC type has greatly reduced preparation time with its easy insert replacement feature. Also, the costs of spare tools for re-grinding has been reduced, and tool life has improved.

(Evaluation by the user)

Q&A

Q-1 Is re-grinding available?

A-1 We don't recommend it. Grinding of edge nose chisel is not possible.

Q-2 How large would the cutting hole be to the insert diameter (øDc)?

A-2 The machining hole with SCM 435, compare to the insert diameter, is about +0.020~+0.040mm.